

# PR TECTOR

by



A RANGE OF SIMPLE, EASY TO USE, REFILLING AND TOP UP UNITS



[iwtm-uk.com](http://iwtm-uk.com)

Email: [info@IWTM-UK.com](mailto:info@IWTM-UK.com)

Phone: 020 8255 2903

## TABLE OF CONTENTS

---

<b>PROTECTOR PROFILL DESCRIPTION</b> .....	<b>2</b>
What is profill? .....	2
How does it work? .....	2
<b>WHY DO WE DEMINERALISE THE FILLING WATER OF HEATING &amp; COOLING SYSTEMS?</b> .....	<b>3</b>
<b>PROCESS OF DEMINERALISATION</b> .....	<b>4</b>
<b>INTERNAL &amp; EXTERNAL VIEW</b> .....	<b>5</b>
<b>SIZING</b> .....	<b>6</b>
Sizing guide requirements .....	6

## PROTECTOR PROFILL DESCRIPTION

### WHAT IS PROFILL?

ProFill is a range of simple, easy to use refilling and top up units for demineralised water for heating and cooling systems. Installed in line with the systems filling device, they ensure that when used with our controlled pH resin that the filling water is supplied in accordance with the VDI 2035 standard.

The range has 4 different sizes, to accommodate your system requirements. 4L, 12.5L, 25L and 50L.

The ProFill filters lime and aggressive substances such as sulphates, nitrates and chlorides out of the fill water. The appliance uses a mixed bed ion exchanger to provide demineralised water for any system size. This method does not emit any chemical additives into the water. The appliance operates without an external power connection.

The resin beads have two types of ionexchange with the untreated water. As the untreated water passes through the ProFill, positively charged ions from the water will swap with positive hydrogen ions on the resin (cation exchange).

Similarly, negative ions in the untreated water will

swap with negative hydroxyl ions on the resin beads (anion exchange). The ions will be exchanged until none is left in the water other than hydrogen and hydroxyl, making H<sub>2</sub>O, demineralised water.

VDI 2035, SWKI Directive BT102-01 and other European standards state that water for filling heating systems should generally be demineralised for low salt operation. Practical experience has shown that even at a low hardness level, modern appliances such as wall mounted gas boilers, heat pumps and solar thermal systems can suffer damage from limescale deposits. Compared to water that has been softened, demineralised water no longer contains any salts. Its electrical conductivity is extremely low, allowing it to act as a corrosion inhibitor.

### HOW DOES IT WORK?

The Protector ProFill operates through the process of demineralisation, where water flows over the ion exchange resin, and through this process, becomes demineralised water suitable for heating and cooling systems. Please go to page 05, for the science behind demineralisation.

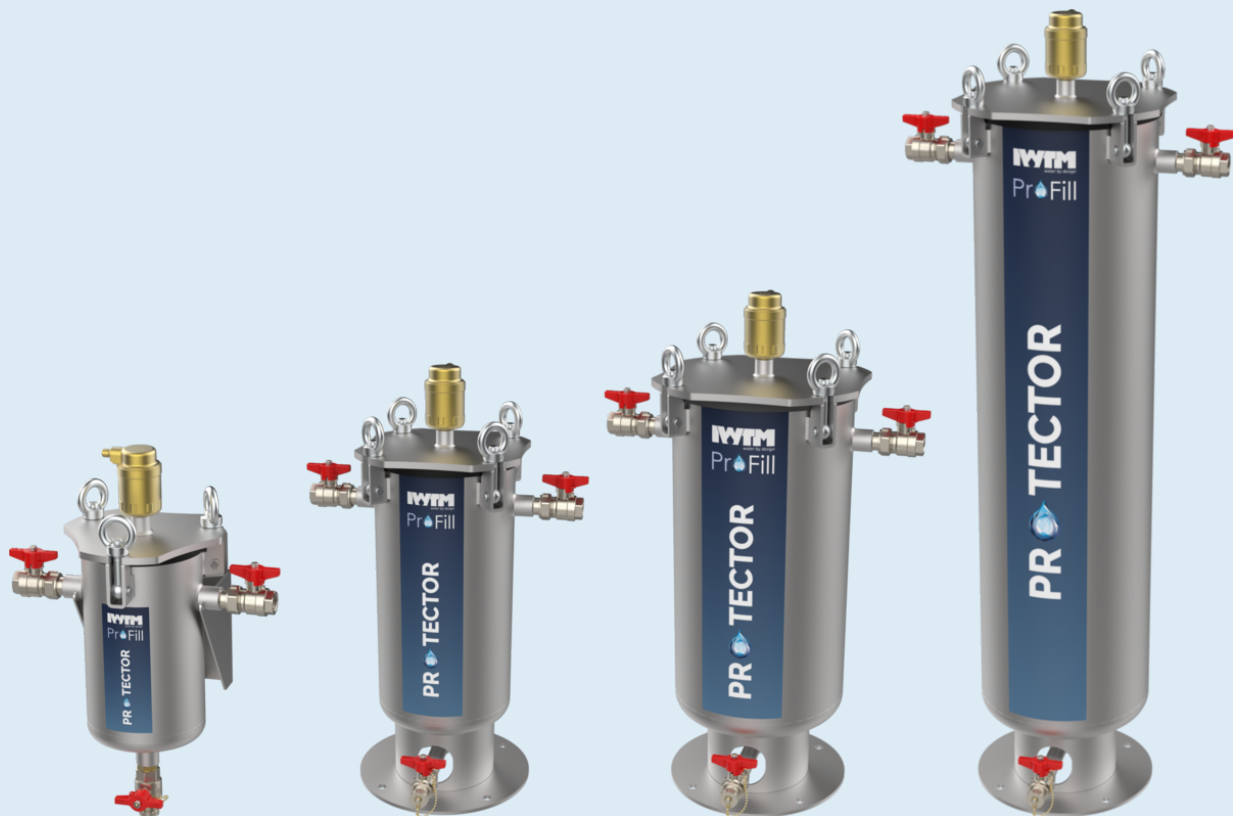

## WHY DO WE DEMINERALISE THE FILLING WATER OF HEATING & COOLING SYSTEMS?

Modern heating systems are sensitive to hard and corrosive filling water. Increased heating loads and more compact heat exchangers result in higher surface temperatures and thus in the formation of limescale build-up, which then prevents a good heat transfer and could limit the efficiency or lead to premature failures and malfunctioning of the system. In addition, materials such as aluminium or stainless steel are also very sensitive when it comes to an improper composition of the water.

For these reasons, many heating and cooling equipment manufacturers require the use of conditioned filling water, the most common to ensure compliance with the guideline VDI 2035 part 1.

The main aim of Guideline VDI 2035 is to prevent scale formation and water-side corrosion damage.

To reach these goals, the Guideline foresees different procedures, demineralisation, hardness stabilisation, and stabilisation of the pH and is applicable to the process of heating water conditioning for water heating installations in accordance with DIN EN 12828 within buildings when the flow temperature does not exceed 100°C.



Limescale on surfaces lead to high temperature differences in the heat exchanger itself - thermal stress causes cracks with leaks.



Limescale in a heating pipe, significant reduction in diameter.

## PROCESS OF DEMINERALISATION

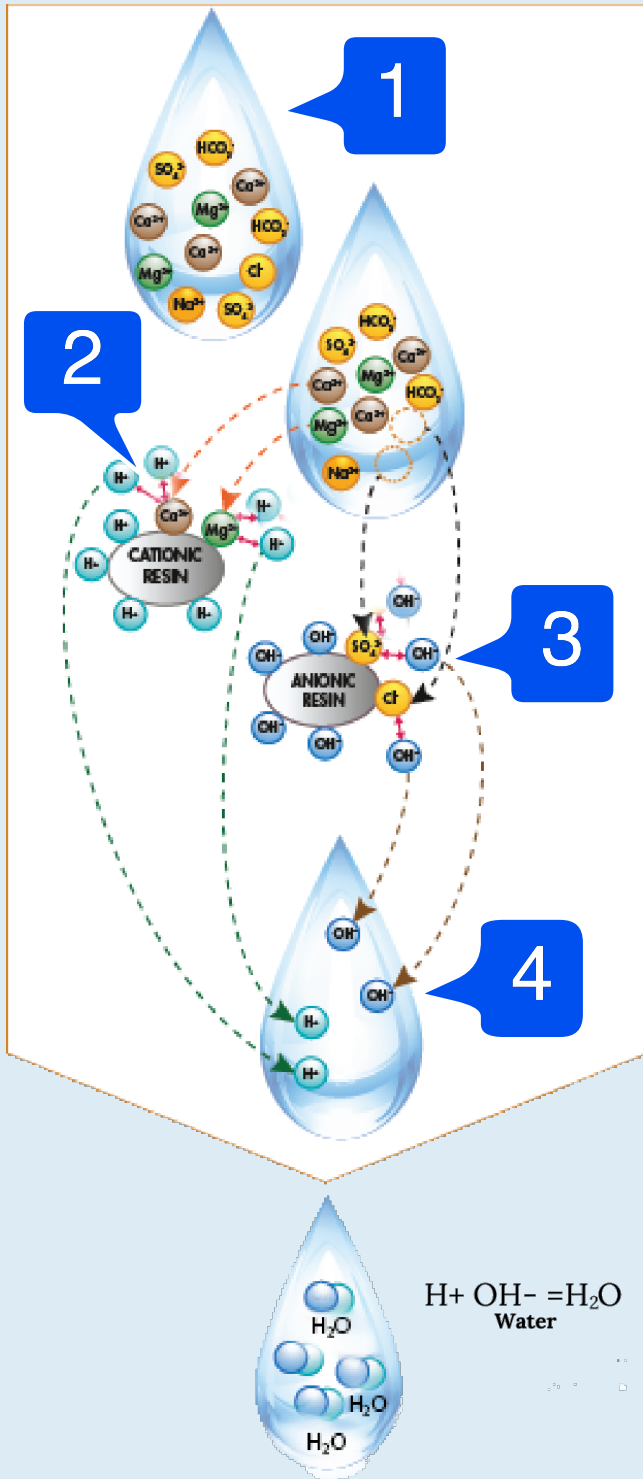

1. The water contains positively charged molecules and negatively charged molecules (salts)
2. The positively charged salts replace the  $H^+$  ions in the resin
3. The negatively charged salts replace the  $OH^-$  ions in the resin
4. The salts are captured by the resins, forming  $H^+$  and  $OH^-$  ions.

The resin beads have two types of ion exchange with the untreated water. As the untreated water passes through the ProFill, positively charged ions from the water will swap with positive hydrogen ions on the resin (Cation exchange).

Similarly, negative ions in the untreated water will swap with negative hydroxyl ions on the resin beads (anion exchange).

The ions will be exchanged until none is left in the water other than hydrogen and hydroxyl ions, making  $H_2O$ , demineralised water.



## INTERNAL & EXTERNAL VIEW



1. Automatic air vent (AAV)
2. Eye bolts on lid for ease of opening and resin changing
3. Service valve and meter kit supplied as standard
4. Flushing and test point valve
5. Actual conductivity, fill rate, volume and resin expiry alarm functions on meter
6. Robust EPDM seal
7. Internal deflector baffle
8. Dip tube with union for removal when required
9. Drain valve for resin removal

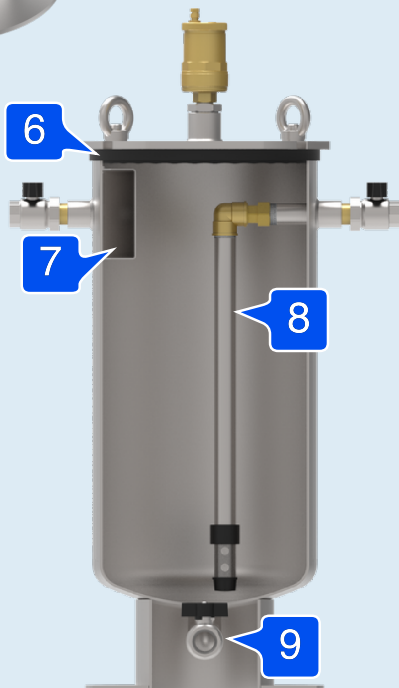

## -sizing

ProFill Unit	Max pressure	Max temperature	Delivery Capacity	Height	Width	Dry weight	Shipping weight
ProFill 4	10 bar	95°C	10 l/min	570 mm	369 mm	20 kg	23 kg
ProFill 12,5	10 bar	95°C	20 l/min	726 mm	420 mm	22 kg	26 kg
ProFill 25	10 bar	95°C	20 l/min	828 mm	474 mm	28 kg	32 kg
ProFill 50	10 bar	95°C	20 l/min	1283 mm	474 mm	38 kg	44 kg

### -sizing guide requirements

A ProFill should ideally be sized to accommodate 1% of the system water volume being replenished per annum for a good heating or cooling installation. The size will depend on the incoming water hardness where the ProFill is being installed. The annual fill rate of the system can be more than 1% in some circumstances and this will affect the selection as a larger unit may be required to accommodate system issues. You can find your water company and then your water hardness guide from your local water provider.

Table showing what the approximate filling capacity in litres is with different water hardness in degrees German °dH , for the ProFill range.

ProFill Unit	2 °dH	7 °dH	15 °dH
ProFill 4	3333	952	666
ProFill 12,5	10000	2857	1333
ProFill 25	20000	5714	2666
ProFill 50	40000	11428	5,332

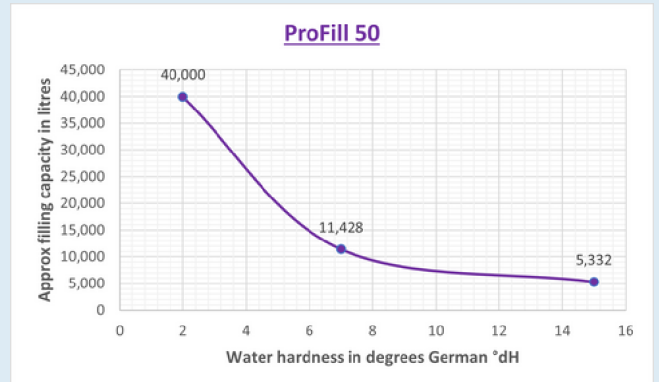
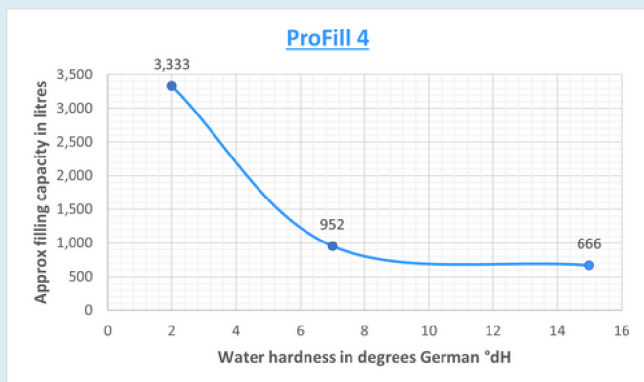
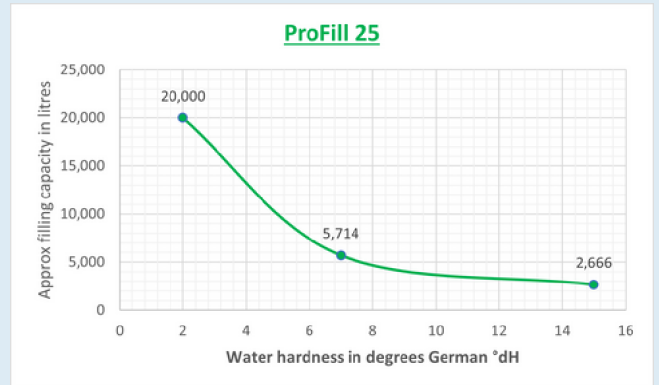
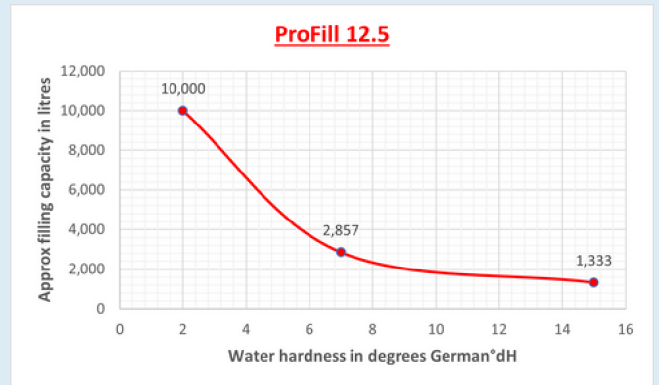

# PROTECTOR

by



IWTM was established in 1992 and has over 30 years of experience in water treatment of technical systems ranging from small single-family homes to nuclear power plants, with a focus on maritime and land-based heating and cooling systems.

DNV issued the world's first certificate for environmentally friendly water treatment "clean machinery and components" in 2003. IWTM is still the only company in the world with this type of certificate.

IWTM Protector is our latest, most innovative product and is built with the future in mind and can be adapted to SDsystems.

## **IWTM UK Ltd**

Sutton Business Centre Restmor Way

Email: [info@IWTM-UK.com](mailto:info@IWTM-UK.com)

Phone: 020 8255 2903

[iwtm-uk.com](http://iwtm-uk.com)